

# 國語教學中心 新生說明會

MANDARIN TRAINING CENTER  
ORIENTATION

March 6<sup>th</sup> 2017



# Welcome to MTC

- ◆ Visa
- ◆ MTC Course
- ◆ Student Affairs

# Visa

# VISA

Extend visa within two weeks of expiry  
Visa may be extended twice for up to  
180 days

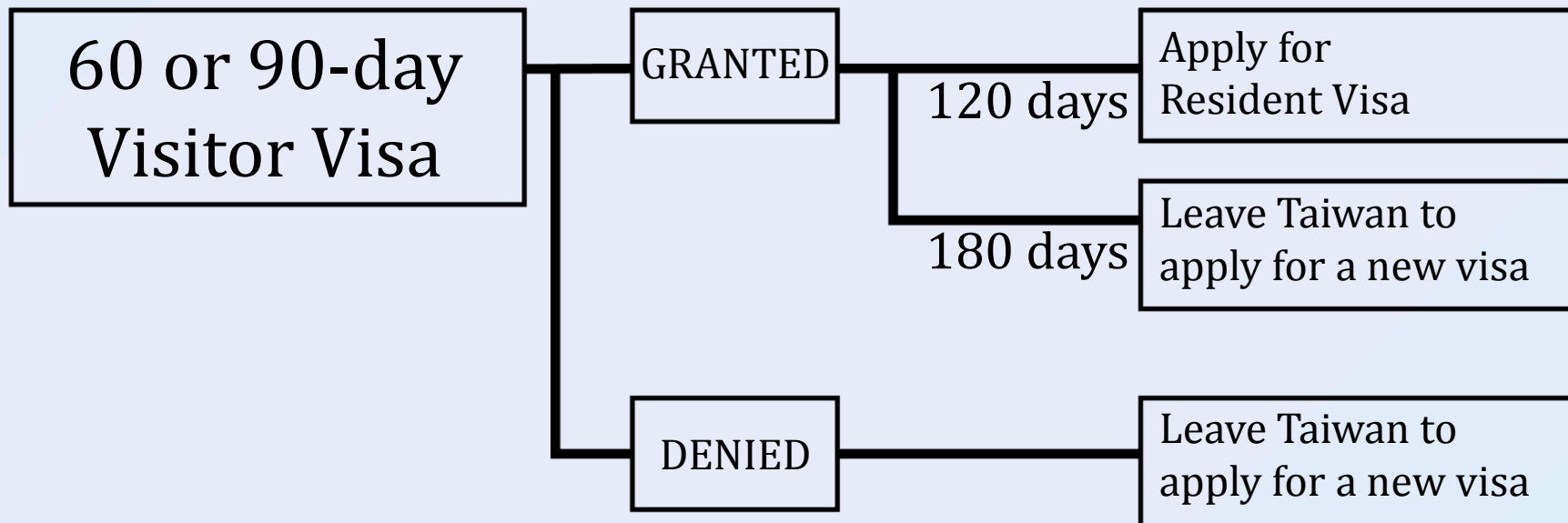

# VISA EXTENSION

Prepay  
tuition  
fees for  
next  
quarter

1. Certificate of Enrollment
2. Attendance Record
3. Current month Attendance

**National  
Immigration  
Agency**

\*Taipei City

\*New Taipei City

# VISA EXTENSION DENIED

- Absent for over 12 hours in a month
- Monthly grade below 60
- Landing visa or non-extendable visa
- Visa code is not “FR”

# APPLY FOR RESIDENT VISA

One month before visa expires

 Medical Exam  
 Tuition Payment

**Ministry of Foreign  
Affairs (MOFA)**

Certificate of Enrollment

Attendance Record

Study Plan

Medical Exam Report

Financial Statement

Passport and 2 passport photos



# ALIEN RESIDENT CERTIFICATE (ARC)

Prepay  
tuition  
fees for  
next  
quarter

1. Certificate of Enrollment
2. Attendance Record
3. Current month attendance
4. Passport and photo

National  
Immigration  
Agency

within  
15 days

# Evening Class

If you enter Taiwan on a Mandarin study visa (code: FR), please DO NOT choose evening classes.

# MTC Classes



# Regular Class



# Intensive Class

3 hrs

every day

# Intensive Class

- Tough and demanding
- Preview and review
- Daily diction test; chapter review test
- If you cannot adhere to class rules, you may want to switch to Regular Class.

# SUPPLEMENTARY CLASS

- **Four types**
- Required study hours per month =  
Number of class days in the month
- Plan your study schedule in advance
- **Library/Labs  $\leq$  3 hrs per day**

# SUPPLEMENTARY CLASS

## TIME CARD

臺灣師範大學國語教學中心語言輔助課紀錄卡 Supplementary Language Class			
學生姓名 Student Name	國籍 Nationality		
學號 Student Number	上課時間 Class Time		
時間 Date / Time	課程名稱 Class Title	節數/小時 Hour	教師簽章 Teacher
14 OCT 06 12:46	閱讀練習	1節	
14 OCT 06 15:10	閱讀練習	1節	
14 OCT 06 16:48	閱讀練習	2節	
14 OCT 07 08:12	閱讀練習	1節	
14 OCT 07 12:35	閱讀練習	2節	
14 OCT 07 14:24	閱讀練習	2節	
14 OCT 08 03:10	中國成語和俗語	2節	
14 OCT 08 10:15	閱讀練習	1節	
14 OCT 08 15:44	閱讀練習	2節	
14 OCT 09 03:10			
14 OCT 09 10:17			
14 OCT 13 08:03			
14 OCT 13 12:22	視聽練習	1節	
14 OCT 13 13:53			
103. 10. 9	唱歌學中文	2節	
14 OCT 13 08:03			
14 OCT 13 10:13			
103. 10. 16	唱歌學中文	2節	

- For Regular Class students
- Handed out by your teacher
- Record study hours
- Signed by your teacher at the end of month
- Required for visa extension
- Extra study hours cannot be transferred to the following month



# SUPPLEMENTARY CLASS

## SUPPLEMENTARY TYPE 1: Large Language Class

**Classroom: R504**

(refer to Large Language Class schedule)

# SUPPLEMENTARY CLASS

## SUPPLEMENTARY TYPE 2:

### Listening Drill

R501, R502, R503

08:30 - 19:00

### Academic Counseling

15 min. per session

Apply at R606

14:20 - 16:10

### Reading Hall

R709

09:00 - 19:00

# SUPPLEMENTARY CLASS

**SUPPLEMENTARY TYPE 3:** Cultural Activity  
Language Contest  
  
Student Activity  
MTC Volunteer

# SUPPLEMENTARY CLASS

## SUPPLEMENTARY TYPE 4:

### Research Project

- TOCFL
- Teaching Materials
- National Science Council Project

### Teacher Training Program

Volunteer Student

# SUPPLEMENTARY CLASS RULES

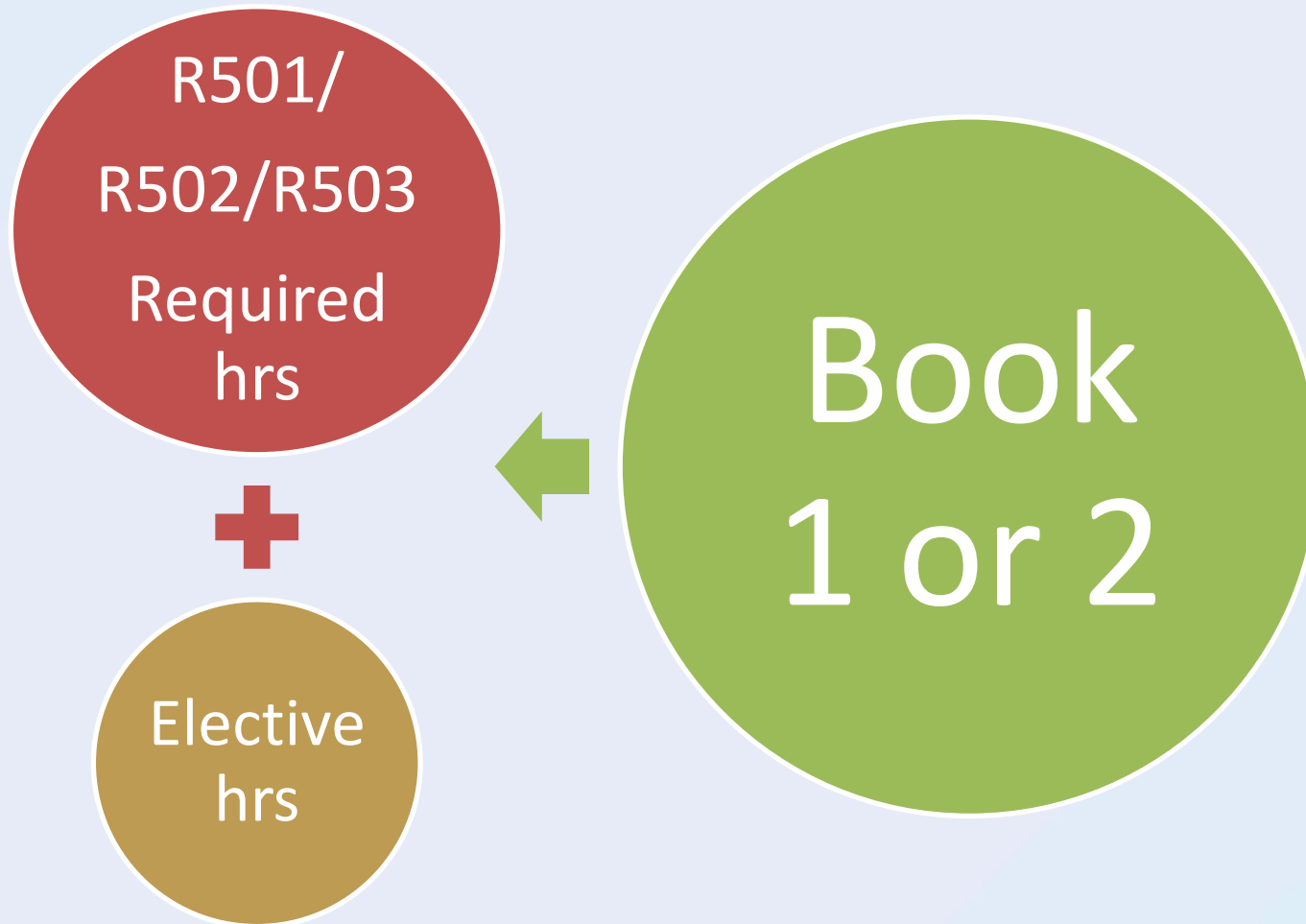

# SUPPLEMENTARY CLASS RULES

R504  
Required  
hrs



Elective  
hrs



Book 3 or  
above  
  
OR  
  
Practical Chinese  
Reading and Writing

# ACHIEVEMENT TEST

Level 1~4:

Achievement Test

Level 3 & above:

Composition





部分課程的收材料費  
Some classes may charge an additional fee for class materials.  
文化課成績會顯示於成績單上，但不列入學期成績  
Culture classes will be shown on student transcript but will not be accredited as Chinese language classes.  
文化課時數可列入每週語言輔助時數  
Culture classes count as supplementary language class hours.  
更多課程相關資訊以及報名，歡迎洽詢612辦公室  
For more information please contact Miss Chen in office 612 desk 7.

註冊繳費  
Registration & Payment  
**3/7~3/13**

報名費用  
Tuition Fee  
**\$4,500NT** CASH ONLY  
2hrs/per week

上課日期  
Class Period  
**3/14~5/26**



中國畫  
Chinese Painting  
王秀華老師  
週三 Wed. 12:20~14:10  
週二 Wed. 14:20~16:10



中國茶藝  
Chinese Tea  
黃杜英老師  
週三 Wed. 14:20~16:10



色香味  
中國美食  
Chinese Cuisine  
呂慧蓮老師  
週三 Wed. 14:20~16:10  
週四 Thu. 12:20~14:10



中國剪紙  
Chinese Paper Cutting  
王秀華老師  
週五 Fri. 12:20~14:10



太極拳  
Tai-chi Chuan  
蔡顯秀老師  
週二 Tue. 14:20~16:10  
陳建昌老師  
週五 Fri. 14:20~16:10



二胡教學  
Erhu  
汪景弘老師  
週二 Tue. 14:20~16:10  
週五 Fri. 14:20~16:10



篆刻藝術  
Chop Engraving  
張宏權老師  
週四 Thu. 14:20~16:10



注音  
Chinese Pronunciation  
陳麗華老師  
週五 Fri. 16:20~18:10



中國剪紙  
Chinese Paper Cutting  
王秀華老師  
週四 Thu. 12:20~14:10



實用台語  
Practical Taiwanese  
蕭惠茹老師  
台語一 Taiwanese 1  
週三 Wed. 14:20~16:10  
週五 Fri. 14:20~16:10  
台語二 Taiwanese 2  
週四 Thu. 14:20~16:10



書法  
Chinese Calligraphy  
張宏權老師  
週二 Tue. 12:20~14:10  
週四 Thu. 12:20~14:10



國術  
Chinese Martial Arts  
王士鈞老師  
週三 Wed. 14:20~16:10



# Culture Class Registration and Payment: Mar. 7 ~ Mar. 13

## Class Schedule: Mar. 14 ~ May. 26

Tuition Fee:  
NT\$4,500

Two hours per week  
for 10 weeks

Apply at Desk 2, Office 612



# Department of Chinese as a Second Language

(Bachelor Program for International Students)

National Taiwan Normal University



Knowledge  
and skills  
pertaining to  
the Chinese  
language

Chinese for  
specific  
purposes

**Curriculum**

Chinese  
culture

Applied  
Chinese and  
teaching  
pedagogy



<http://www.tcsi.ntnu.edu.tw/>

一起學中文！

- E-mail: [clc@ntnu.edu.tw](mailto:clc@ntnu.edu.tw)
- TEL: +886-2-7734-5187
- FAX: +886-2-2341-9746

謝謝！

國立臺灣師範大學國語教學中心  
Mandarin Training Center National Taiwan Normal



# CLASS CHANGE WEEK

**Mar. 7 ~ Mar. 13**

Class change forms will be made available on Mar. 7<sup>th</sup> outside Office 612 by the bulletin board.



# CLASS CHANGE PROCEDURE

(once per term)

**Look  
for a  
seat**

Visit  
new  
class



**Drop  
your  
class**

Obtain  
teacher's  
signature



**Audit**

2 hours  
max.



**New  
class**

Obtain  
new  
teacher's  
signature



**Return  
the  
form**

Desk 8,  
R612

# Tuition Payment & Refund

Regular Class ↔ Intensive Class

Tuition difference: NT\$9600

Apply at Desk 6, Office 612: Mar. 15 ~ Mar. 21

Please refer to student guide book for  
refund and tuition transfer policy

# Student Affairs

# ATTENDANCE

Sign your name on the  
class roster every class





# LEAVE OF ABSENCE

1. Leave of Absence form (R612)
2. Teacher's signature
3. Desk 1, Office 612

**Absence hours are indicated on Record of Study regardless of absence reasons.**

# 3-in-1 STUDENT ID CARD

- 1-year ISIC membership
- Discounts at stores on NTNU campus
- Emergency contact number at the back



# MTC FACILITIES



Wireless  
Connection

R601

NT\$300/quarter

Student ID



Language Lab

R501, R502, R503



Computer Room

R604



Library

R709

# NTNU FACILITIES

## Gym

NT\$500 for 1 month

NT\$1,000 for 2 months

NT\$1,200 for 3 months

## Swimming Pool

NT\$1,300 for 1 month

NT\$2,300 for 2 months

NT\$3,300 for 3 months

## NTNU Library

NT\$300/term

NT\$2,000 deposit

## Lohas Clinic

Go to Office 614 for clinic schedule

# R614 & R612



- General Information
- Visa Information
- Scholarship Students
- Work Permit Application
- Career plans, Psychological problems



## Smoke-free Campus

NOT allowed in any campus building and anywhere on campus

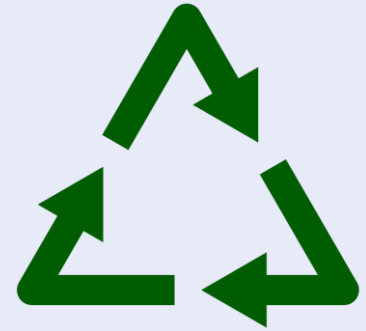

## Recycle

Sort trash into specific categories



## Anti-sexual Harassment

# LIVING IN TAIWAN

## Accidental Insurance

Desk 6, R612

## 24-hour Hotline for Foreigners in Taiwan

0800-024-111

## NTNU Emergency Line

(02)7734-1119

(02)7734-1110

## Useful Link

[www.tealit.com](http://www.tealit.com)

[www.forumosa.com](http://www.forumosa.com)

[www.taiwan.net.tw/welcome.aspx](http://www.taiwan.net.tw/welcome.aspx)

# PICK UP CLASS SCHEDULE

7F

1. Present your Student ID

2. Check: Course Title

Teacher's Name

Classroom Number

Class Time

3. Purchase textbook

Class starts on March 6<sup>th</sup>



# GUIDED TOURS

Please fill out the **Evaluation Form**  
before leaving the auditorium.

Place it in the **box** near the exit  
or pass it to one of our **volunteers!**

